



ModbusRTU

Gas cooler series RC 1.1

Many gas analysis processes require extracting sample gas from the process. This also extracts process-related contamination such as particles or moisture. These can impact the measurement results or damage the measuring cells. The sample gas must therefore be conditioned before entering the analyser. The sample gas cooler reduces the gas temperature to below the dew point for this purpose, causing moisture to drop out, which is then discharged as condensate.

In addition to the status output to monitor the sample gas cooler function, we offer an optional 4 – 20 mA analog output or digital interface. The process control can access the process and diagnostic data via the Modbus RTU interface as well as configure the device settings.

The RC 1.1 is a compressor sample gas cooler designed for high cooling output and high ambient temperatures. Depending on the application, it can be configured with one or two gas paths. This makes it a vital cooling component in sophisticated analysis systems.

Compact design: Pre-installed and ready to connect

Choose from one or two gas paths

Heat exchanger made from stainless steel, Duran glass and PVDF

Adjustable outlet dew point and alarm thresholds

Cooling block temperature display

Status display and output

Rated cooling power 360 kJ/h

Constant dew point stability ± 0.1 °C

Optional 4 - 20 mA or Modbus RTU signal output

Moisture detector, filter and condensate pump optional

Successor to the EGK 1/2 and EGK 1SD



Gas cooler technical data

Gas Cooler Technical Data

Ready for operation	after max. 15 minutes		
Rated cooling capacity (at 25 °C)	360 kJ/h		
Ambient temperature	5 °C to 50 °C		
Gas outlet dew point			
preset:	5 °C		
adjustable:	3 °C to 20 °C		
Dew point fluctuations			
static:	± 0.1 K		
in the entire specification range:	± 1.5 K		
IP rating	IP 20		
Housing	Stainless steel		
Packaging dimensions	approx. 420 x 440 x 350 mm		
Weight incl. heat exchanger	approx. 16,0 kg		
Electric supply	115 V, 60 Hz or 230 V, 50/60 Hz ± 5% Plug per DIN EN 175301-803		
Electrical data		230 V	115 V
	Typical power input:	396 VA	402 VA
	max. operating current:	2.5 A	5 A
Alarm output switching connection	max. 250 V, 2 A, 50 VA Connector per DIN EN 175301-803		
Installation	stand-alone or wall-mounted		

Technical Data - Options

Technical Data Peristaltic Pumps CPsingle / CPdouble

Ambient temperature	0 °C to 60 °C		
Flow rate	0.3 L/h (50 Hz) / 0.36 L/h (60 Hz) with standard hose		
Vacuum inlet	max. 0.8 bar		
Pressure inlet	max. 1 bar		
Outlet pressure	1 bar		
Hose	4 x 1.6 mm		
Condensate outlet	Hose nipple Ø6 mm Screw connection 4/6 (metric), 1/6"-1/4" (US)		
Protection class	IP 40		
Materials			
Hose:	Norprene (Standard), Marprene, Fluran		
Connections:	PVDF		

Analogue Output Cooler Temperature Technical Data

Signal	4-20 mA or 2-10 V corresponds to -20 °C to +60 °C cooler temperature		
Connection	M12x1 plug, DIN EN 61076-2-101		

Digital interface technical data

Signal	Modbus RTU (RS-485)		
Connection	M12x1 connector, DIN EN 61076-2-101		

Technical Data Filter AGF-PV-30-F2-L

Ambient temperature	3 °C to 100 °C
max. operating pressure with filter	4 bar
Filter surface	125 cm ²
Filter fineness	2 µm
Dead volume	108 ml
Materials	
Filter:	PVDF, Duran glass (parts in contact with mediums)
Seal:	Viton
Filter element:	sintered PTFE

Technical Data FF-3-N Moisture Detector

Ambient temperature	3 °C to 50 °C
max. operating pressure with FF-3-N	2 bar
Material	PVDF, PTFE, epoxy resin, stainless steel 1.4571, 1.4576

Performance data

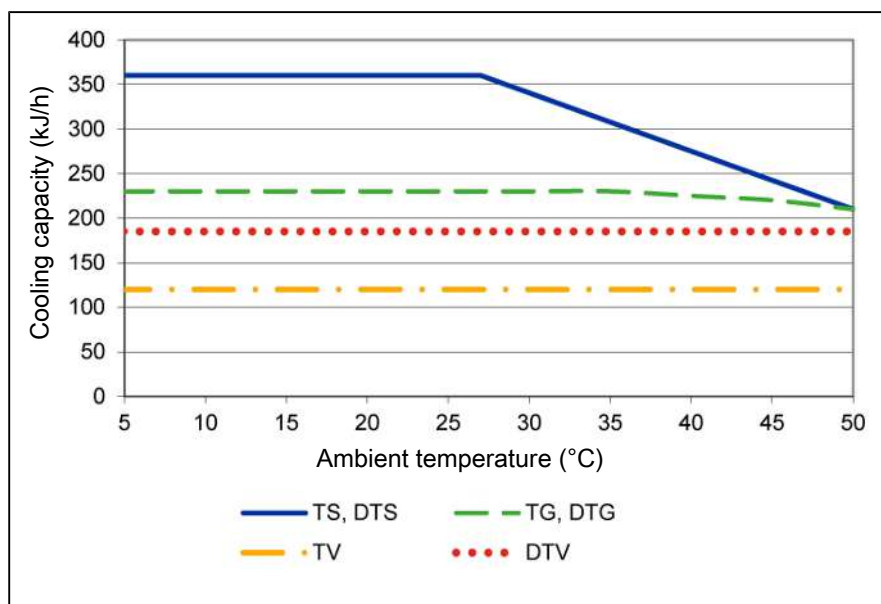

Note: The limit curves for the heat exchangers exchanger apply to a dew point of 65 °C.

Diagram typical installation

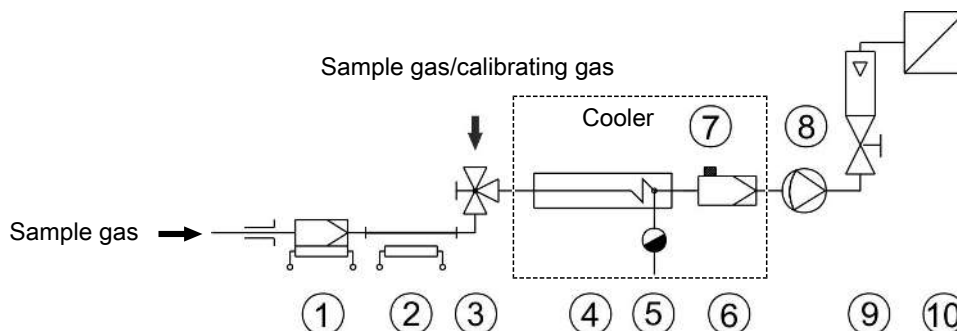

1 Sample gas probe	2 Sample gas line
3 Reversing tap	4 Sample gas cooler
5 Automatic condensate drain or peristaltic pump	6 Fine mesh filter
7 Moisture detector	8 Sample gas pump
9 Flow meter	10 Analyser

See data sheets for individual component types and data.

Heat exchanger description

The energy content of the sample gas and the required cooling capacity of the gas cooler is determined by three parameters: gas temperature ϑ_G , (inlet) dew point τ_e (moisture content) and volume flow v . The outlet dew point rises with increasing energy content of the gas. The approved energy load from the gas is therefore determined by the tolerated rise in the dew point.

The following limits are specified for a normal standard operating point of $\tau_e = 65^\circ\text{C}$ and $\vartheta_G = 90^\circ\text{C}$. The maximum volume flow v_{\max} in NI/h of cooled air is indicated, so after moisture has condensed.

If the values fall below τ_e and ϑ_G , the flow v_{\max} may be increased. For example, on the TG heat exchanger the parameter triple $\tau_e = 65^\circ\text{C}$, $\vartheta_G = 90^\circ\text{C}$ and $v = 280$ NI/h may also be used in place of $\tau_e = 50^\circ\text{C}$, $\vartheta_G = 80^\circ\text{C}$ and $v = 380$ NI/h

Please contact our experts for clarification or refer to our design program.

Heat exchanger overview

Heat exchanger	TS TS-I ²⁾	TG TG	TV-SS TV-SS-I ²⁾	DTS (DTS-6 ³⁾) DTS-I (DTS-6-I ³⁾) ²⁾	DTG DTG	DTV ³⁾ DTV-I ^{2) 3)}
Materials in contact with media	Stainless steel	Glass PTFE	PVDF	Stainless steel	Glass PTFE	PVDF
Flow rate v_{\max} ¹⁾	530 L/h	280 L/h	155 L/h	2 x 250 L/h	2 x 140 L/h	2 x 115 L/h
Inlet dew point $\tau_{e,\max}$ ¹⁾	80 °C	80 °C	65 °C	80 °C	65 °C	65 °C
Gas inlet temperature $\vartheta_{G,\max}$ ¹⁾	180 °C	140 °C	140 °C	180 °C	140 °C	140 °C
Max. Cooling capacity Q_{\max}	450 kJ/h	230 kJ/h	120 kJ/h	450 kJ/h	230 kJ/h	185 kJ/h
Gas pressure p_{\max}	160 bar	3 bar	3 bar	25 bar	3 bar	2 bar
Pressure drop Δp ($v=150$ L/h)	8 mbar	8 mbar	8 mbar	5 mbar each	5 mbar each	15 mbar each
Dead volume V_{tot}	69 ml	48 ml	129 ml	28 / 25 ml	28 / 25 ml	21 / 21 ml
Gas connections (metric)	G1/4	GL 14 (6 mm) ⁴⁾	DN 4/6	6 mm tube	GL14 (6 mm) ⁴⁾	DN 4/6
Gas connections (US)	NPT 1/4"	GL 14 (1/4") ⁴⁾	1/4"-1/6"	1/4" tube	GL14 (1/4") ⁴⁾	1/4"-1/6"
Condensate out connections (metric)	G3/8	GL 25 (12 mm) ⁴⁾	G3/8	Tube 10 mm (6 mm)	GL18 (10 mm) ⁴⁾	DN 5/8
Condensate out connections (US)	NPT 3/8"	GL 25 (1/2") ⁴⁾	NPT 3/8"	Tube 3/8" (1/4")	GL18 (3/8") ⁴⁾	3/16"-5/16"

¹⁾ Max. cooling capacity of the cooler must be considered

²⁾ Models marked I have NPT threads or US tubes, respectively.

³⁾ Condensate drain only possible with condensate pump

⁴⁾ Gasket inside diameter

Dimensions

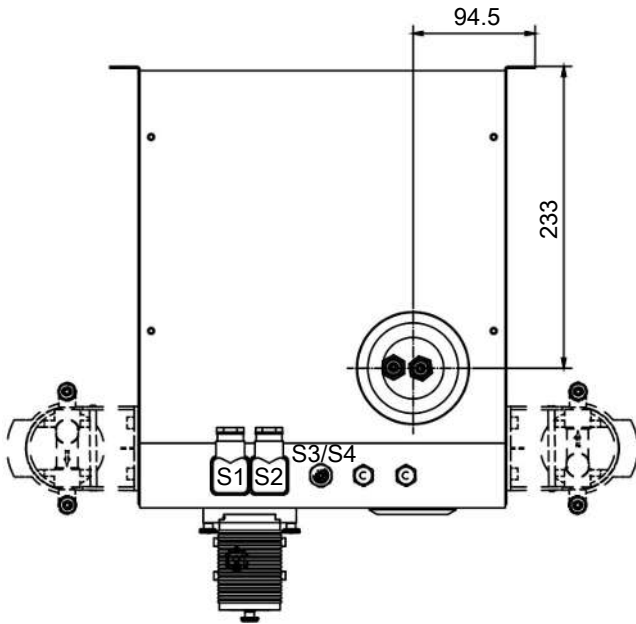
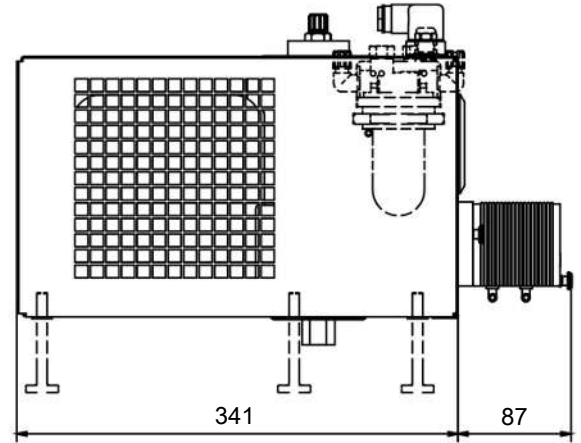
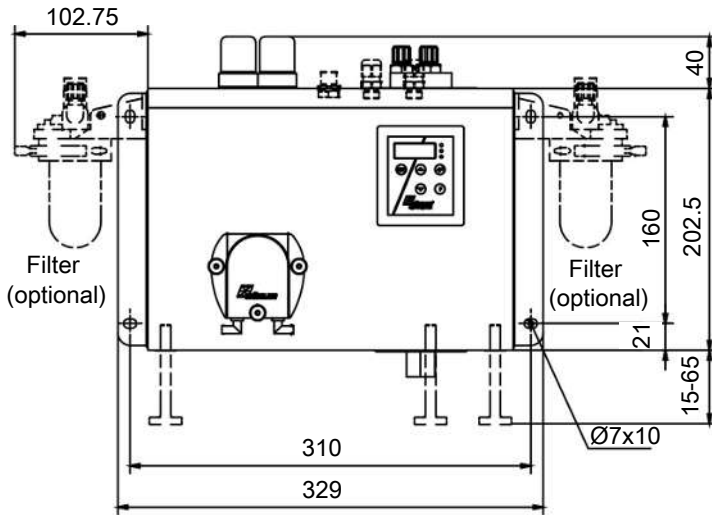

- S1 = Electric supply
- S2 = Alarm contact
- S3/S4 = Analog/digital output (optional)

Ordering instructions

Gas cooler

The item number is a code for the configuration of your unit. Please use the following model key:

4596	2	1	1	0	X	X	X	X	X	0	X	X	X	0	0	0	0	0	Product Characteristics
Voltage																			
1																			115 V, 60 Hz
2																			230 V, 50/60 Hz
Heat exchanger																			
1 1 0																			1 gas path, stainless steel/ (TS), metric
1 1 5																			1 gas path, stainless steel/ (TS-I), US
1 2 0																			1 gas path, glass/ (TG), metric
1 2 5																			1 gas path, glass/ (TG), US hoses
1 3 0																			1 gas path, PVDF/ (TV), metric
1 3 5																			1 gas path, PVDF/ (TV-I), US
2 6 0																			2 gas paths, stainless steel/ (DTS), metric
2 6 1																			2 gas paths, stainless steel/ (DTS-6) ¹⁾ , metric
2 6 5																			2 gas paths, stainless steel/ (DTS-I), US
2 6 6																			2 gas paths, stainless steel/ (DTS-6-I) ¹⁾ , US
2 7 0																			2 gas paths, glass/ (DTG), metric
2 7 5																			2 gas paths, glass/ (DTG-I), US hoses
2 8 0																			2 gas paths, PVDF/ (DTV) ¹⁾ , metric
2 8 5																			2 gas paths, PVDF/ (DTV-I) ¹⁾ , US
Condensate drain²⁾																			
0 0																			without condensate drain
1 0																			CPsingle with adapter, angled ³⁾
2 0																			CPdouble with adapter, angled ³⁾
3 0																			CPsingle with screw connection, metric/US ³⁾
4 0																			CPdouble with screw connection, metric/US ³⁾
Filter/moisture detector																			
0 0																			without filter, without moisture detector
0 1																			without filter, 1 moisture detector
0 2																			without filter, 2 moisture detectors
0 3																			Moisture detector in stainless steel adapter
0 4																			2 moisture detectors in stainless steel adapter
1 0																			1 filter, without moisture detector
1 1																			1 filter, 1 moisture detector
1 2																			1 filter, 2 moisture detectors
2 0																			2 filters, without moisture detector
2 1																			2 filters, 1 moisture detector
2 2																			2 filters, 2 moisture detectors
Signal outputs																			
0 0																			status output only
1 0																			Analog output, 4..20 mA, incl. status output
2 0																			Modbus RTU digital output, incl. status output

¹⁾ Condensate outlets only suitable for connecting peristaltic pumps.

²⁾ Peristaltic pumps also available for separate installation, see data sheet 450020.

³⁾ Supply voltage corresponds with that of the main unit.

Spare Parts and Accessories

Item no.	Description
41020050	Filter element F2-L; unit 2 count (for type RC 1.1)
41030050	Filter element F2; unit 5 count (for type RC 1.2+)
4410001	Automatic condensate drain 11 LD V 38
4410004	Automatic condensate drain AK 20, PVDF
4410005	Condensate trap GL 1; glass, 0.4 L
4410019	Condensate trap GL 2; glass, 1 L
459600026	Adapter plate EGK 1/2 to RC 1.1 and RC 1.2+
see data sheet 410001	Fine mesh filter AGF-PV-30
see data sheet 450020	Peristaltic Condensate Pumps CPsingle, CPdouble